

- 50% smaller than standard hybrid modules.
- Standard Frequencies; 315, 433MHz
- Frequencies Available: 300-450MHz
- Very High Frequency Stability (No Adjustable Components).
- Receiving Range Up To 50 Metres.
- CMOS/TTL Compatible Output.
- Compatible With R.F. Solutions AM Transmitters.
- Patented Laser Trimmed Inductor.
- Compliant To ETSI300-220.
- Requires No Radio Licence To Operate.

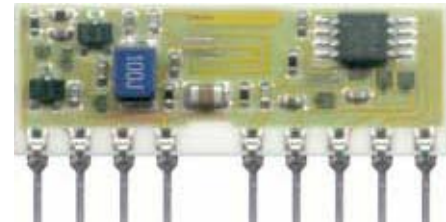

Description

The R.F. Solutions Miniature AM 'Super Regen' Receiver module is an extremely compact hybrid RF receiver, which can be used to capture undecoded data from any AM Transmitter, such as R.F. Solutions AM-RT4 / 5 range of transmitters. (See AM Transmitter datasheet DS013).

These modules show a very high frequency stability over a wide operating temperature even when subjected to mechanical vibrations or manual handling. A unique laser trimming process which has been patented gives a very accurate on board inductor, removing the need for any adjustable components.

All receivers are compatible, producing a CMOS/TTL output, and require connections to power and antenna only.

RF Solutions also offer a range of Super Heterodyne Receivers, for data on these products (please see Datasheet DS017).

Block Diagram

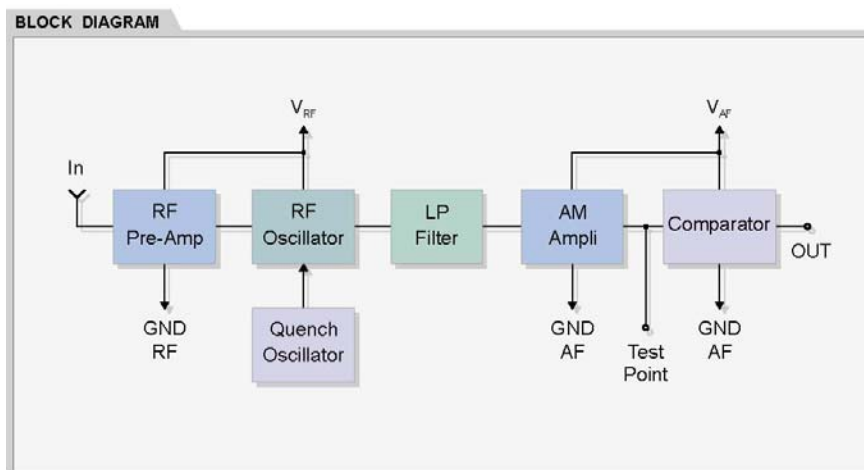

Part Numbers

The following modules are available from stock although any frequency between 300-450MHz is available upon request.

Part Number	Description
AM-HRR30-433	Compact Hybrid Receiver Module, 433MHz
AM-HRR60-433	Compact Hybrid Receiver Module, 433MHz

Mechanical Details

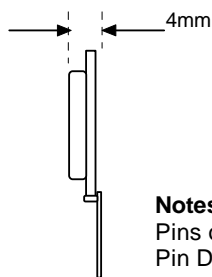
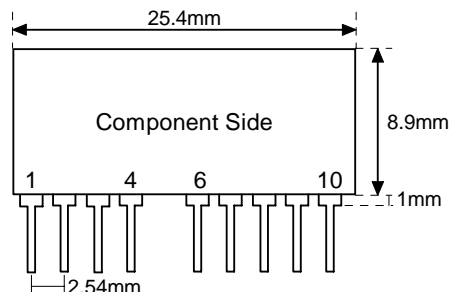

Notes
 Pins on 0.1" pitch
 Pin Dims :0.25 x 0.50mm

Pin	Pin Name
1	RF +Vcc
2	RF GND
3	DATA IN (Ant)
4	RF GND
6	AF GND
7	AF +VCC
8	TEST POINT
9	DATA OUT
10	AF +VCC

Electrical Characteristics

Ambient temperature = 25° Celsius.

ELECTRICAL CHARACTERISTICS	MIN	TYPICAL	MAX	DIMENSION
Operating Temperature Range	-25		+80	°C
Tuning Tolerance		± 0.2	± 0.5	MHz
Receiver Frequency (315 MHz versions)		315		MHz
Receiver Frequency (433 MHz versions)		433.92		MHz
Supply Voltage	4.5	5	5.5	V
Supply Current		2.5	3	mA
Data Rate	50		4800	bits/Sec
R.F Sensitivity 100% AM	-100	-105		dBm
-3dB Bandwidth		± 2	± 3	MHz
Conducted Spurious Emissions			-60	dBm
High Level Output Voltage	3.6			V
Low Level Output Voltage			0.6	V

Application Circuit

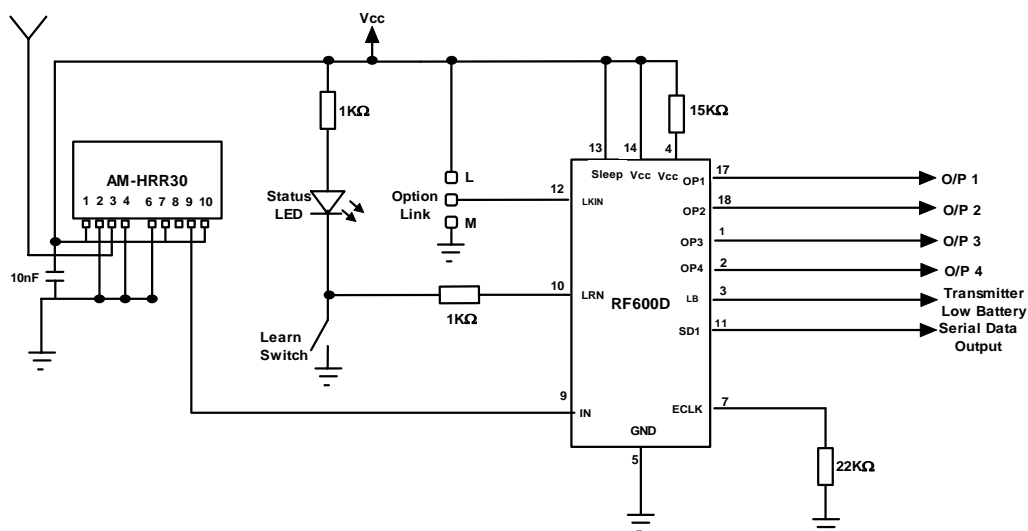

For further information on this circuit please see datasheet DS600

**R. F. Solutions Ltd,
 Unit 21, Cliffe Industrial Estate,
 South Street, Lewes,
 E Sussex, BN8 6JL. England.**

Tel +44 (0)1273 898 000. Fax +44 (0)1273 480 661.

Web Site <http://www.rfsolutions.co.uk> Email sales@rfsolutions.co.uk